

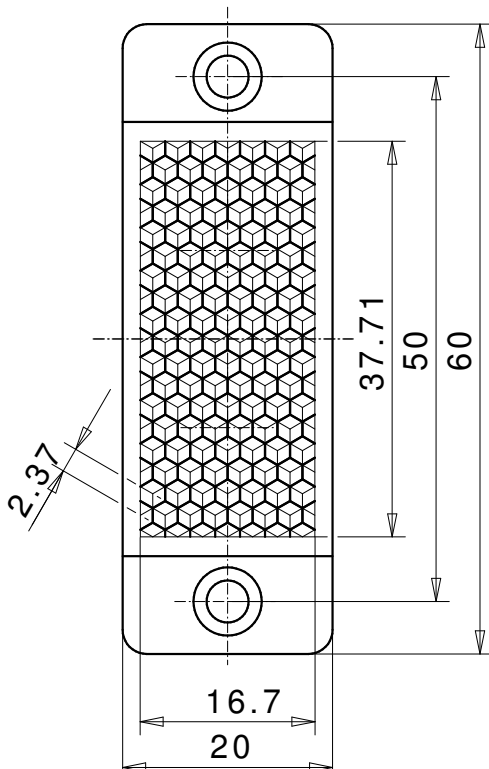

## Reflector for photoelectric sensor 20x40 G chem ZSB

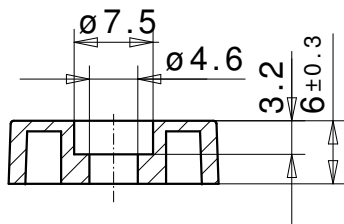

### REFLECTOR DATA

|             |                                    |
|-------------|------------------------------------|
| Application | Reflector for photoelectric sensor |
| Item        | 20x40 G chem ZSB                   |
| Item no.    | 09042510                           |

### TECHNICAL SPECIFICATIONS

|                       |                               |
|-----------------------|-------------------------------|
| Shape                 | angular                       |
| Size (LxWxH)          | 60x20x6 mm                    |
| Reflective size (LxW) | 37,7x16,7 mm                  |
| Tolerance             | TG5 [DIN 16742]               |
| Mounting              | to be screwed                 |
| Chemical resistance   | increased chemical resistance |
| Protection            | IP68                          |
| Operating temp.       | -20°C to +65°C                |
| Surface               | Standard                      |
| Optical structure     | hexagonal                     |
| Optic size            | Standard triple SW2,3         |
| Polarizing rotation   | yes                           |
| Application           | Standard sensors              |

### MATERIAL DATA

|                    |            |
|--------------------|------------|
| Material reflector | PMMA clear |
| Material bracket   | PET blue   |

### DESCRIPTION

Due to the material used, encapsulated CHEM reflectors are resistant to many chemicals that conventional reflectors are not resistant to. This ensures a significantly longer service life in critical applications and lowers operating costs, as these reflectors are significantly less expensive than glass or stainless steel encapsulated reflectors. The reflection values are nearly the same as those of the standard reflectors. The Chem reflectors are ECOLAB certified