

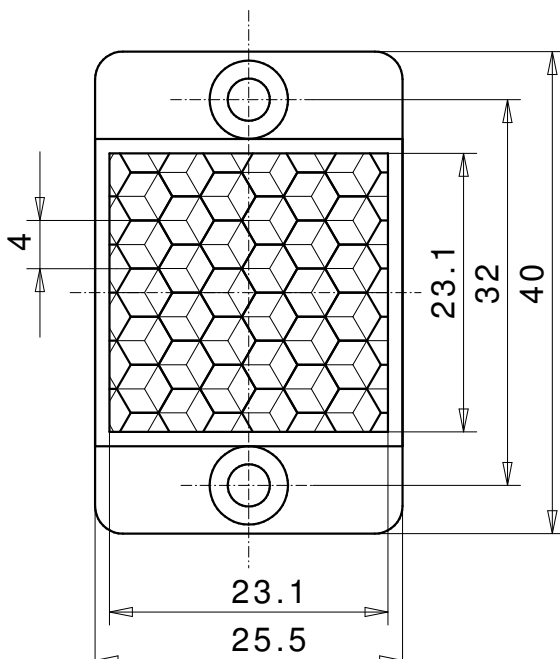

Reflector for photoelectric sensor 25x25 LH ZSB

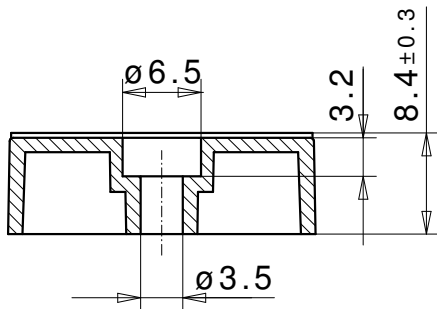

REFLECTOR DATA

Application	Reflector for photoelectric sensor
Item	25x25 LH ZSB
Item no.	00092510

TECHNICAL SPECIFICATIONS

Shape	angular
Size (LxWxH)	40x25,5x8,4 mm
Reflective size (LxW)	23,1x23,1 mm
Tolerance	TG5 [DIN 16742]
Mounting	to be screwed
Chemical resistance	Standard
Protection	IP68
Operating temp.	-20°C to +65°C
Surface	Standard
Optical structure	hexagonal
Optic size	Standard triple SW4
Polarizing rotation	yes
Application	Standard sensors

MATERIAL DATA

Material reflector	PMMA clear
Material bracket	PMMA high impact white

DESCRIPTION

The standard reflectors have highest reflection values and ranges. These reflectors are best suited for applications with standard sensors.