

Reflector for photoelectric sensor 30x50 LH ZSB

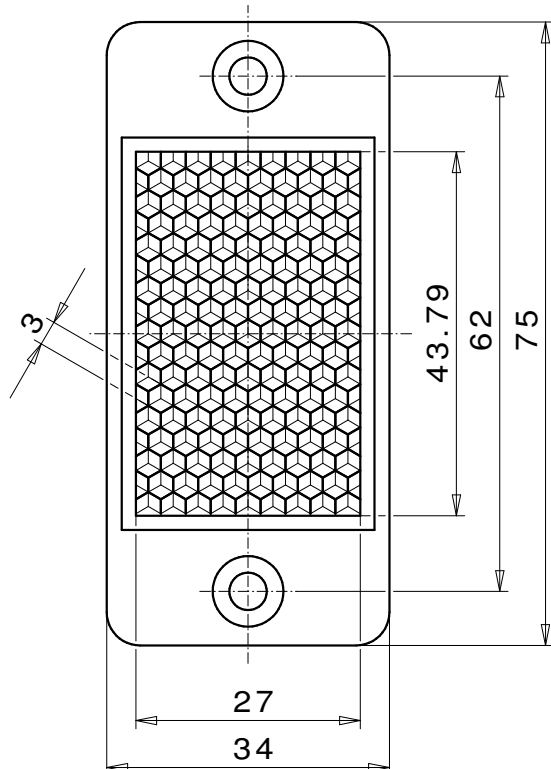
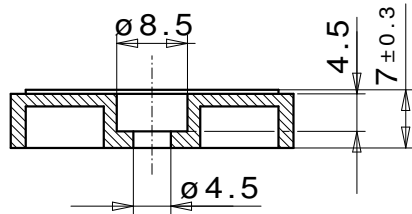

REFLECTOR DATA

Application	Reflector for photoelectric sensor
Item	30x50 LH ZSB
Item no.	93152510

TECHNICAL SPECIFICATIONS

Shape	angular
Size (LxWxH)	75x34x7 mm
Reflective size (LxW)	43,3x27 mm
Tolerance	TG5 [DIN 16742]
Mounting	to be screwed
Chemical resistance	Standard
Protection	IP68
Operating temp.	-20°C to +65°C
Surface	Standard
Optical structure	hexagonal
Optic size	Standard triple SW3
Polarizing rotation	yes
Application	Standard sensors

MATERIAL DATA

Material reflector	PMMA clear
Material bracket	PMMA high impact white

DESCRIPTION

The standard reflectors have highest reflection values and ranges. These reflectors are best suited for applications with standard sensors.