

# Reflector for photoelectric sensor

## 40x180 2Bo ZSB

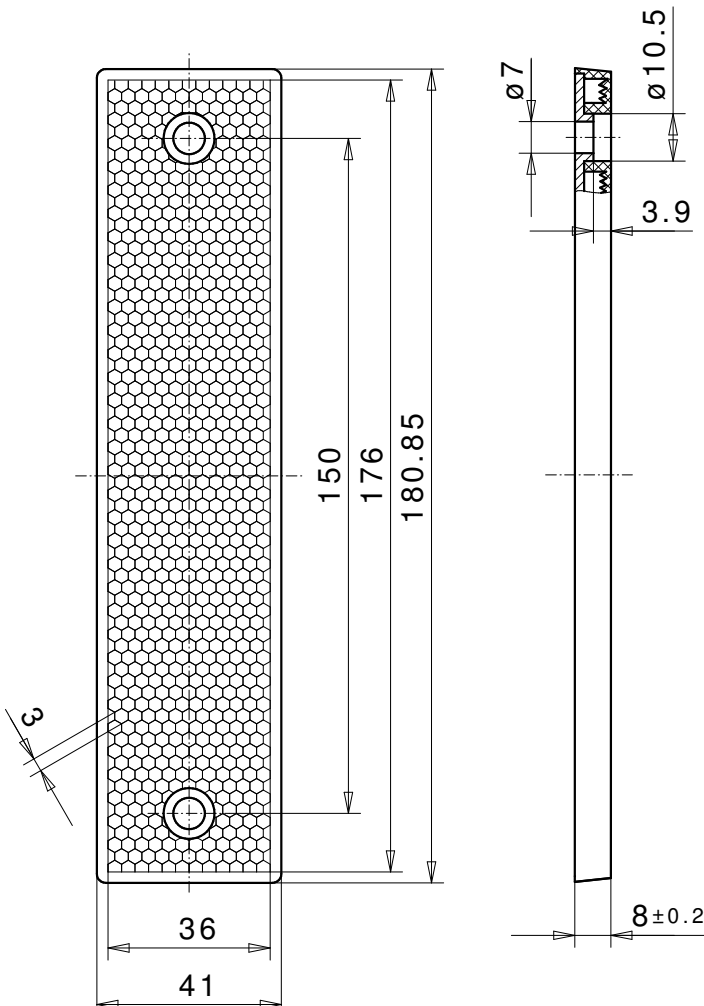

### REFLECTOR DATA

Application	Reflector for photoelectric sensor
Item	40x180 2Bo ZSB
Item no.	80232510

### TECHNICAL SPECIFICATIONS

Shape	angular
Size (LxWxH)	180,85x41x8 mm
Reflective size (LxW)	176x36 mm
Tolerance	TG5 [DIN 16742]
Mounting	to be screwed
Chemical resistance	Standard
Protection	IP68
Operating temp.	-20°C to +65°C
Surface	Standard
Optical structure	hexagonal
Optic size	Standard triple SW3
Polarizing rotation	yes
Application	Standard sensors

### MATERIAL DATA

Material reflector	PMMA clear
Material bracket	PMMA high impact white

### DESCRIPTION

The standard reflectors have highest reflection values and ranges. These reflectors are best suited for applications with standard sensors.