

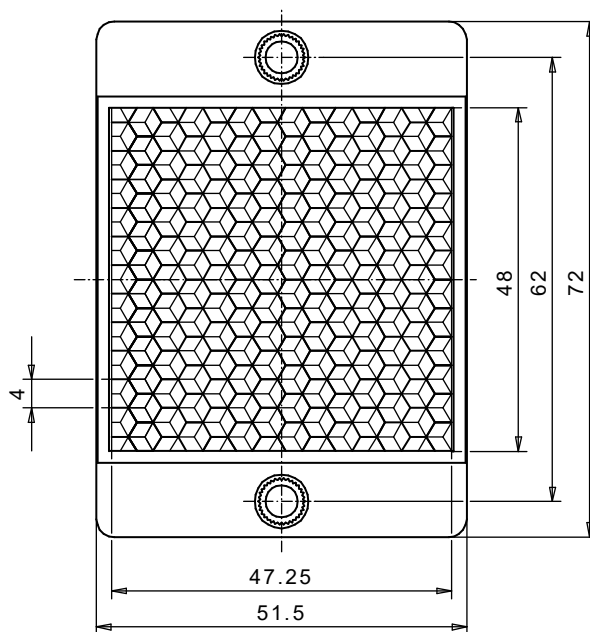

Reflector for photoelectric sensor

50x50 LHF HT ZSB

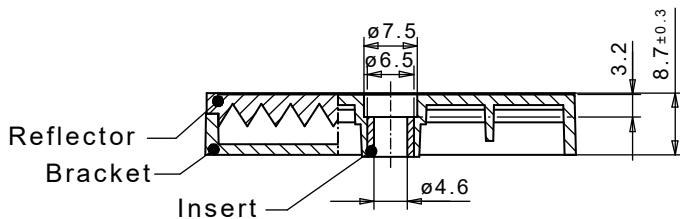

REFLECTOR DATA

Application	Reflector for photoelectric sensor
Item	50x50 LHF HT ZSB
Item no.	07602570

TECHNICAL SPECIFICATIONS

Shape	angular
Size (LxWxH)	72x51,5x8,7 mm
Reflective size (LxW)	48x47,25 mm
Tolerance	TG5 [DIN 16742]
Mounting	to be screwed
Chemical resistance	Standard
Protection	IP40
Operating temp.	-20°C to +120°C
Surface	Standard
Optical structure	hexagonal
Optic size	Standard triple SW4
Polarizing rotation	yes
Application	Standard sensors

MATERIAL DATA

Material reflector	PC clear
Material bracket	PC grey
Material insert	brass

DESCRIPTION

Reflectors of this type are made of high-temperature-resistant plastic, which is characterized by a very high heat resistance and at the same time has very good optical properties. As a result, the reflectors are temperature-resistant up to 120 ° C, the reflection properties correspond approximately to those of the standard reflectors. For air exchange, they are equipped with a vent hole. If watertightness is required, the reflectors can be provided with an additional membrane.