

## Reflector for photoelectric sensor 60D 2 Bo ZSB

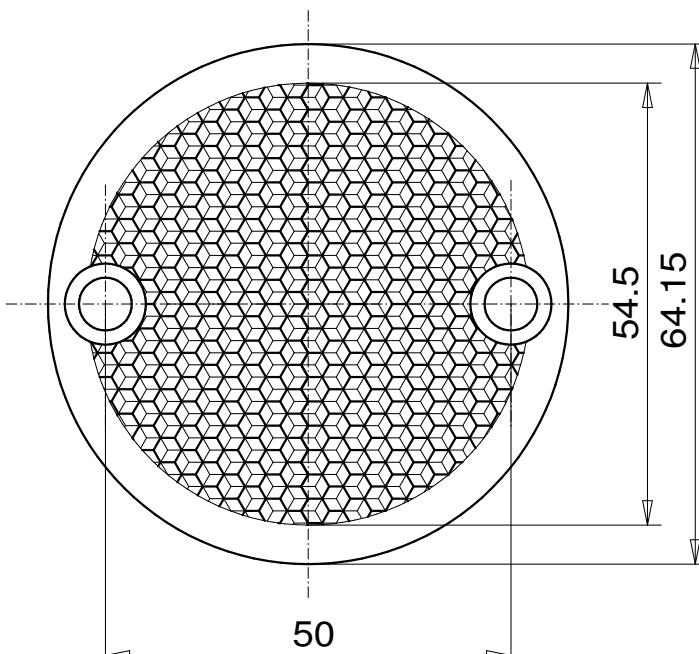
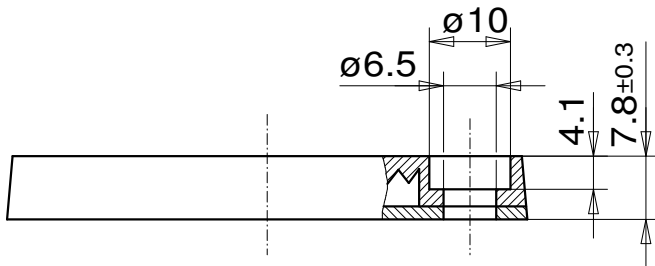

### REFLECTOR DATA

Application	Reflector for photoelectric sensor
Item	60D 2 Bo ZSB
Item no.	80272510

### TECHNICAL SPECIFICATIONS

Shape	round
Size(ØxHeight)	64,15x7,8 mm
Reflective size (Ø)	54,5mm
Tolerance	TG5 [DIN 16742]
Mounting	to be screwed
Chemical resistance	Standard
Protection	IP65
Operating temp.	-20°C to +65°C
Surface	Standard
Optical structure	hexagonal
Optic size	Standard triple SW3
Polarizing rotation	yes
Application	Standard sensors

### MATERIAL DATA

Material reflector	PMMA clear
Material bracket	PMMA high impact white

### DESCRIPTION

The standard reflectors have highest reflection values and ranges. These reflectors are best suited for applications with standard sensors.